

DATA SHEET

ES-3535-6006V-XX-UV-275

ES-3535-6006V-XX-UV-275 Datasheet

The 3535 LED light source is a high-performance energy-saving device that can handle high heat and high drive current.

The Purple LED light source with peak wavelength ranging from 270nm to 280nm.

This part has a foot print that is compatible to most of the same size LED in the market today.

FEATURES

- Deep UV LED with emission wavelength between 260nm to 280nm
- Compatible with reflow soldering process
- Low thermal resistance
- Long operation life
- Wide viewing angle at 120°
- Superior ESD protection
- Environmental friendly, RoHS compliance

APPLICATIONS

- Personal hygiene
- Portable devices
- Water disinfection
- Surface disinfection
- Air disinfection

Note:

The information in this document is subject to change without notice.

PACKAGE DIMENSIONS

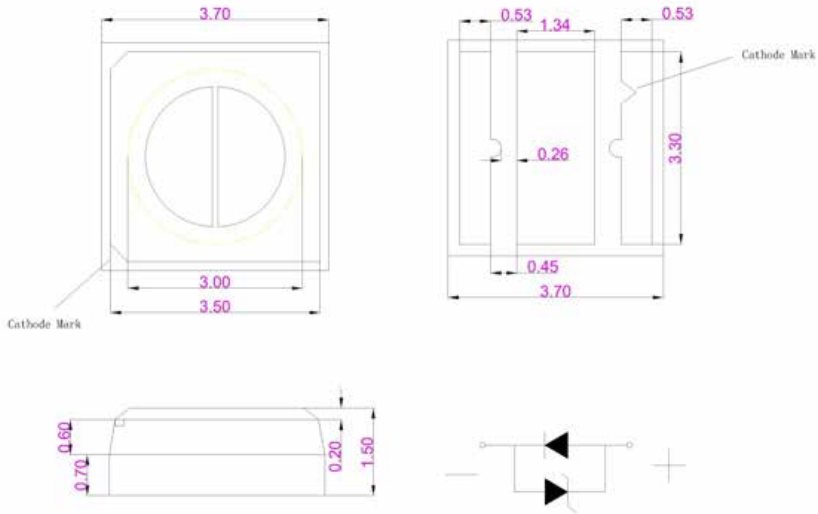

Recommended Solder Pad Design

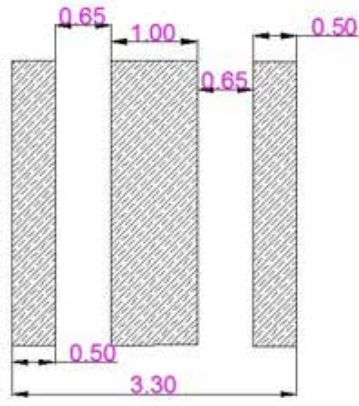
**Note:**

1. All dimensions in millimeters.
2. Thickness tolerance of copper plate is $\pm 0.02\text{mm}$.
3. Thickness tolerance of product is $\pm 0.05\text{mm}$.
4. Tolerance is $\pm 0.1\text{mm}$ unless otherwise noted.

ABSOLUTE MAXIMUM RATINGS (Ta=25°C)

Parameter	Symbol	Value	Unit
Forward current	I _F	100	mA
Peak Forward Current	I _{FP}	150	mA
Reverse Voltage	V _R	5	V
Power Dissipation	P _d	600	mW
Operating Temperature	T _{opr}	-40~+80	°C
Storage Temperature	T _{stg}	-40~+80	°C
Soldering Temperature	T _{slid}	Reflow Soldering: 260°C for 10 seconds	
LED Junction Temperature	T _j	80	°C

CHARACTERISTICS (Ta=25°C)

Parameter	Symbol	Condition	Min.	Typ.	Max.	Unit
Reverse Current	I _R	VR=5V	--	--	10	UA
Forward Voltage	V _F	IF=100mA	5.0	5.8	7.0	V
Viewing Angle	2θ _{1/2}	IF=100mA	--	120	--	deg.
Luminous Intensity	Φ _e	IF=100mA	8	10	15	mw
Peak wavelength	λ _P	IF=100mA	--	275	--	nm

Note:

1. Luminous Intensity is measured with an accuracy of ± 5%.
2. peak wavelength is measured with an accuracy of ± 5%.
3. All measurements were made under the standardized environment of Everstar

RELATIVE SPECTRAL POWER DISTRIBUTION (T_j=25°C)

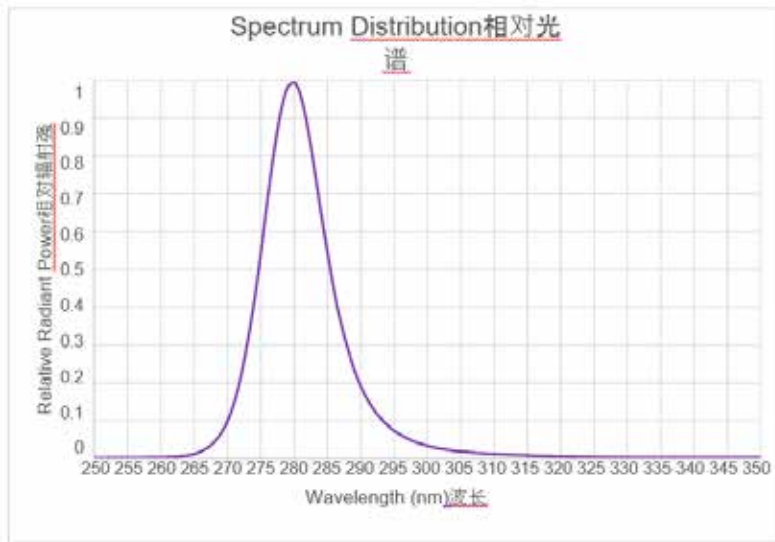

TYPICAL SPATIAL DISTRIBUTION

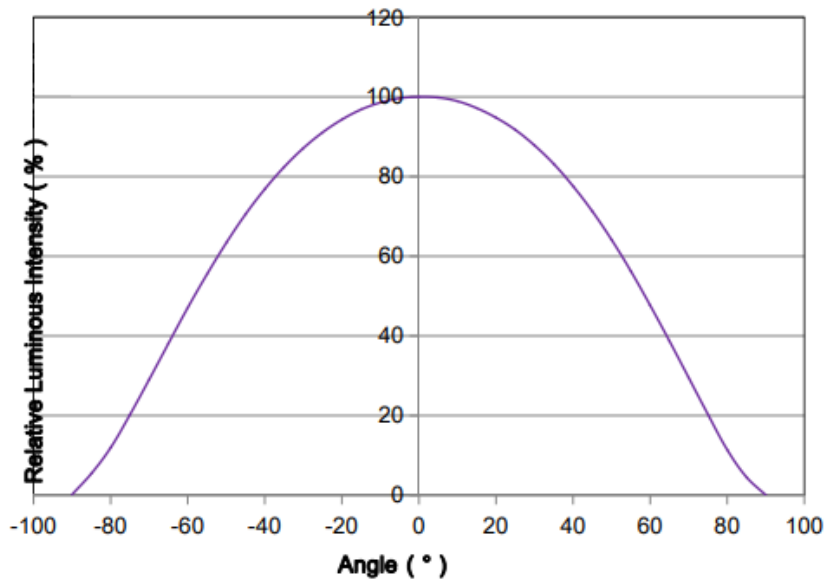

RELATIVE LUMINOUS FLUX VS. CURRENT ($T_j=25^{\circ}\text{C}$)

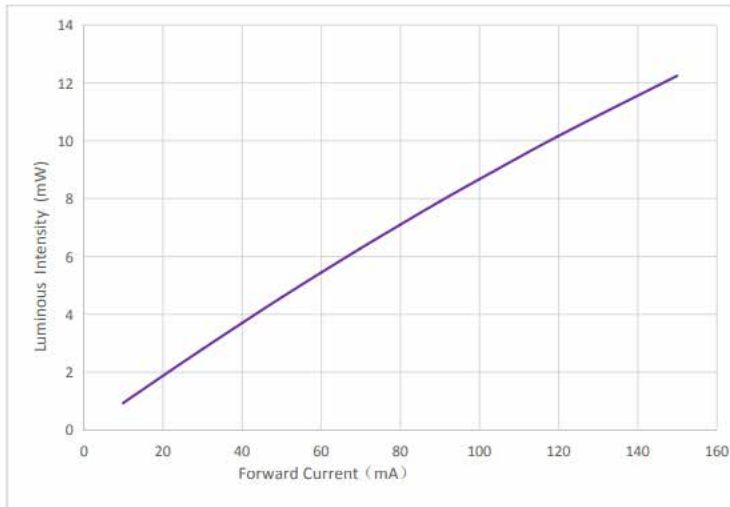

ELECTRICAL CHARACTERISTICS ($T_j=25^{\circ}\text{C}$)

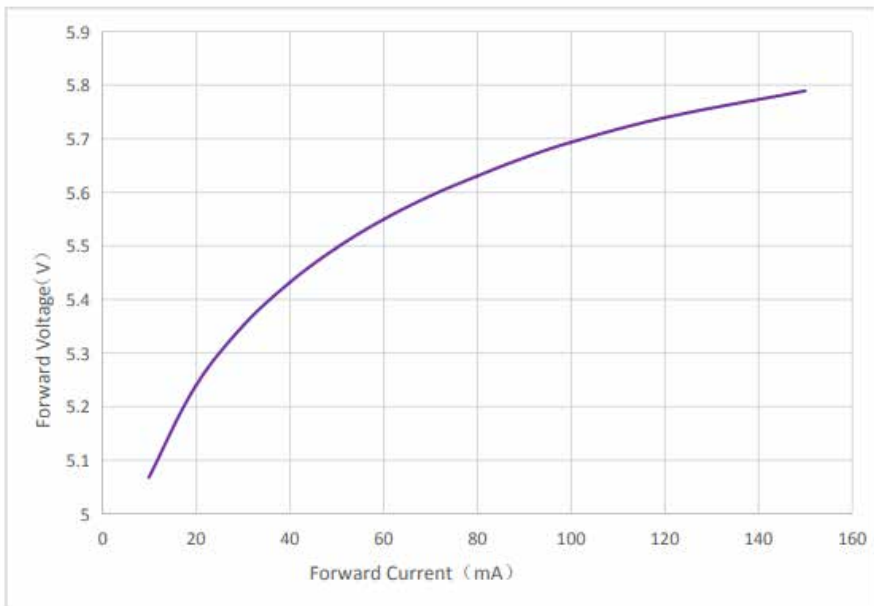

SORTING RANKS

(1) Luminous Intensity (T_j=25°C)

Part No.	Condition	Rank		Unit
ES-3535-6006V-XX-UV-275	100mA	LK	MA	MW
		8.5-10	10-12	
		MD	MC	
		12-14	14-16	

(2) Forward Voltage (T_j=25°C)

Rank	Condition	Min.	Max.	Unit
CD	100mA	5.2	5.6	V
CE		5.6	6.0	
DA		6.0	6.4	
DB		6.4	6.8	

(3) peak wavelength (T_j=25°C)

Rank	Condition	Rank		Unit
ES-3535-6006V-XX-UV-275	100mA	QB	QC	nm
		260-270	270-280	
		QD		

Note:

- 10% tolerance for luminous intensity may be caused by measurement inaccuracy.
- Measurement Uncertainty of the Forward Voltage : ± 0.03V

REFLOW SOLDERING CHARACTERISTICS

For Reflow Process

Preheating: $140^{\circ}\text{C}\sim 160^{\circ}\text{C}\pm 5^{\circ}\text{C}$, within 2 minutes.

Operation heating: 260°C (Max.) within 10 seconds.(Max)

260°C within 10 seconds.

Gradual Cooling (Avoid quenching).

Lead solder		Lead-free solder	
Pre-heat	120-150°C	Pre-heat	150-200°C
Pre-heat time	120 sec.Max.	Pre-heat time	120 sec.Max.
Peak Temperature	240°C Max.	Peak Temperature	260°C Max.
Soldering time condition	10 sec.Max.	Soldering time condition	10 sec.Max.

<p style="text-align: center;">Lead Solder</p>	<p style="text-align: center;">Lead-free Solder</p>
--	---

Note:

The encapsulated material of the LEDs is silicone . Therefore the LEDs have a soft surface on the top of package. The pressure to the top surface will be influence to the reliability of the LEDs. Precautions should be taken to avoid the strong pressure on the encapsulated part. So when using the picking up nozzle, the pressure on the silicone resin should be proper

RELIABILITY TEST ITEMS

Test Items	Test Duration	Number of Damaged
Steady State Operating Life of High Temperature (HTOL) $T_s=85^{\circ}\text{C}$, IF=Max	1000hrs	0/20
Steady State Operating Life of Low Temperature (LTOL) $T_a=-40^{\circ}\text{C}$, IF=Max	1000hrs	0/20
Pulse Wet Operating Life of High Temperature (PWHTOL) $60^{\circ}\text{C}/90\%\text{RH}$, IF30mins ON/30min OFF	500hrs	0/20
High Temperature Storage (HTS) $^{\circ}\text{C } 80^{\circ}\text{C}$	1000hrs	0/20
Low Temperature Storage (LTS) -40°C	1000hrs	0/20
Thermal Shock (TS) $-45^{\circ}\text{C}\sim 125^{\circ}\text{C}$ 30min dwell 20sec transfer	100cycles	0/20
Solder Resistance (SR) 265°C , 3X MSL	5sec	0/20
Solder Ability (SA) 245°C 5sec, 95% coverage	5sec	0/11
Mechanical Shock (MS) 1500G 0.5msec pulse shock	Each 6 axis	0/6
Random Vibration (RV) 6G RMS, 10-2000Hz, 10min	Per axis	0/6
Variable Vibration Frequency (VVF) 10-2000-10Hz, log or linear sweep rate, 20G for 1 min, 1.5mm each apply 3x per axis over	6hrs	0/6
Salt Spread (SS) 35°C , 30g/m ² /day	48hrs	0/11

Item	Symbol	Test Condition	Criteria for Judgment	
			Min.	Max.
Forward Voltage	V_F	IF=Typical Current		U.S.L x1.1
Luminous Intensity	mW	IF=Typical Current	L.S.L x0.7	
peak wavelength	nm	IF=Typical Current		U.S.L x1.1

PRECAUTION FOR USE

- (1) This device should not be used in any type of fluid such as water, oil, organic solvent, etc. When washing is required, IPA should be used.
- (2) When the LEDs are illuminating, operating current should be decided after considering the ambient maximum temperature.
- (3) LEDs must be stored to maintain a clean atmosphere. If the LEDs are stored for 3 months or more after being shipped from Everstar, a sealed container with a nitrogen atmosphere should be used for storage.
- (4) The LEDs must be used within seven days after opening the moisture proof packing.
Repack unused Products with anti-moisture packing, fold to close any opening and then store in a dry place.
- (5) The appearance and specifications of the product may be modified for improvement without notice.
- (6) This LED is sensitive to the static electricity and surge. It is recommended to use a wrist Band or anti-electrostatic glove when handling the LEDs.
- (7) On manual soldering, a solder tip must be needed as grounded for usage. If over voltage which exceeds the absolute maximum rating is applied to LEDs, it will cause damage LEDs and result in destruction. Damaged LEDs will show some unusual characteristics such as leak current remarkably increase ,turn-on voltage becomes lower and the LEDs get unlighted at low current.