

A large graphic of a magnifying glass with a blue handle and frame, and a yellow lens. The lens contains the title text.

DATA SHEET
ES-3030-PL-AI
HORTICULTURE

CONTENTS

1.	Introduction and features.....	2
2.	Applications.....	2
3.	Package dimensions.....	3
4.	Absolute maximum ratings.....	4
7.	Characteristic and curves	4
8.	Reflow solder characteristics.....	12
9.	Packaging specification.....	13



ES-3030-PL-AI Datasheet

This 3030 LED Light Source is a high performance energy efficient device which can handle high thermal and high driving current. The small package outline and high intensity make it an ideal choice for LED panel light, LED bulb light, LED tube light and etc.

This part has a foot print that is compatible to most of the same size LED in the market today.

This product is designed for flowering and fruiting plants and can be used for most shade and neutral flowering plants as well as for fruiting plants. Adding a small amount of green light can increase the lighting effect. The photosynthetic photon flux efficiency (@ 1W) > 2.3umol/J can meet the requirements of promoting plant growth. More higher PPF/W recommended at 0.5W.



FEATURES

- High luminous Intensity and high efficiency
- Compatible with reflow soldering process
- Low thermal resistance
- Long operation life
- Wide viewing angle at 120°
- Silicone encapsulation
- Environmental friendly, RoHS compliance
- suitable spectrum for leafy vegetables and fruiting plants

APPLICATIONS

- Flat panel light
- LED tube light
- LED bulb light
- Horticulture light

PACKAGE DIMENSIONS

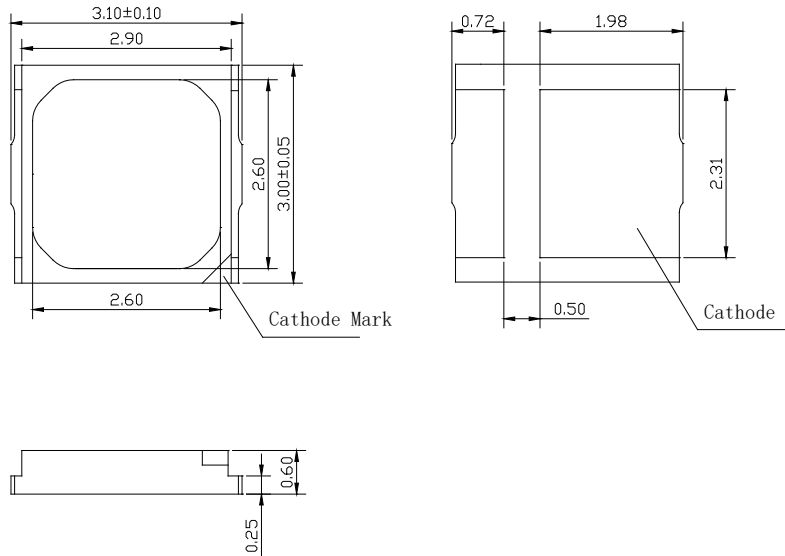

Recommended Solder Pad Design

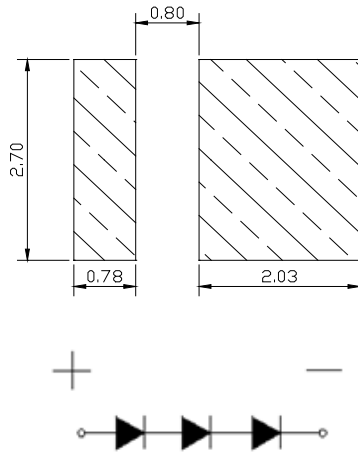

Notes:

1. All dimensions in millimeters.
2. Thickness tolerance of copper plate is ± 0.02 mm.
3. Thickness tolerance of product is ± 0.05 mm.
4. Tolerance is ± 0.1 mm unless otherwise noted.

ABSOLUTE MAXIMUM RATINGS

Item	Symbol	Absolute Maximum Rating	Unit
Forward current	I_F	120	mA
Peak Forward Current ^[1]	I_{FP}	400	mA
Reverse Voltage	V_R	15	V
Power Dissipation	P_d	1056	mW
Operating Temperature	T_{opr}	-40~+85	°C
Storage Temperature	T_{stg}	-40~+100	°C
Soldering Temperature	T_{sld}	Reflow Soldering: 260°C for 10 seconds	
LED Junction Temperature	T_j	115	°C

Note:

I_{FP} Conditions: Pulse Width ≤ 10 msec. and Duty $\leq 1/10$.

CHARACTERISTICS (T_j=25°C)

Item	Symbol	Condition	Min	Typ	Max	Unit
Forward Voltage	V_F	$I_F=100$ mA	8.4	8.6	8.8	V
Viewing Angle	$2\theta_{1/2}$	$I_F=100$ mA	--	120	--	deg.
Luminous Flux	Φ_v	$I_F=100$ mA	80	--	100	lm
Thermal Resistance (Junction to Solder point)	R_{th-js}	$I_F=100$ mA	--	15	--	°C/W
Radiation power	Φ_e	$I_F=100$ mA	--	385	--	mw
Photon flux	PPF	$I_F=100$ mA	--	2.02	--	umol/s
Photon flux efficiency	PPF/W	$I_F=100$ mA	--	2.36	--	umol/s/W

Notes:

- Luminous flux is measured with an accuracy of $\pm 10\%$.
- Chromaticity coordinate bins are measured with an accuracy of ± 0.01 .
- CRI is measured with an accuracy of ± 2 .
- Some color and CRI bins may have limited availability, please contact us before ordering.
- All measurements were made under the standardized environment of Everstar

RELATIVE SPECTRAL POWER DISTRIBUTION (Tj=25°C)

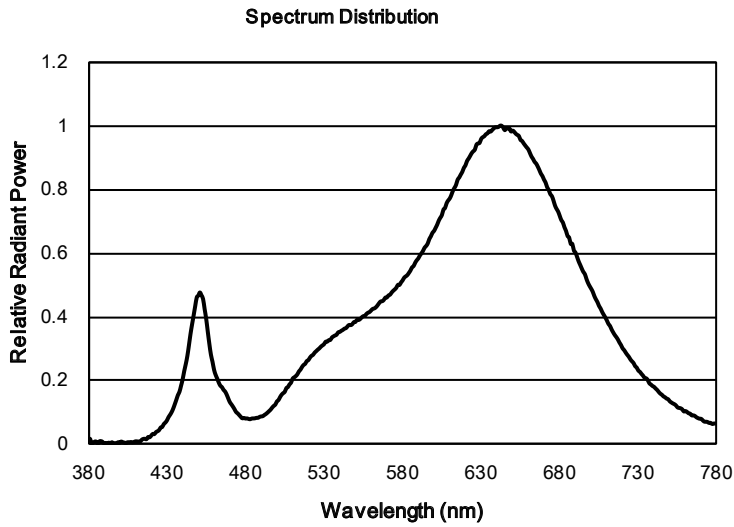

Note:

Radiation power ratio: (380nm-500nm):(500nm-600nm):(600nm-700nm):(700nm-780nm)=9:26:54:11

TYPICAL SPATIAL DISTRIBUTION

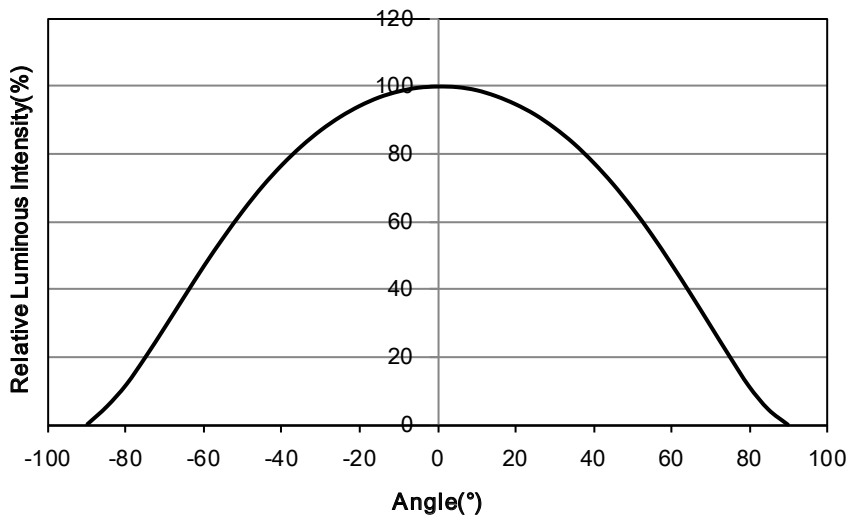

PPF/W VS. CURRENT(Tj=25°C)

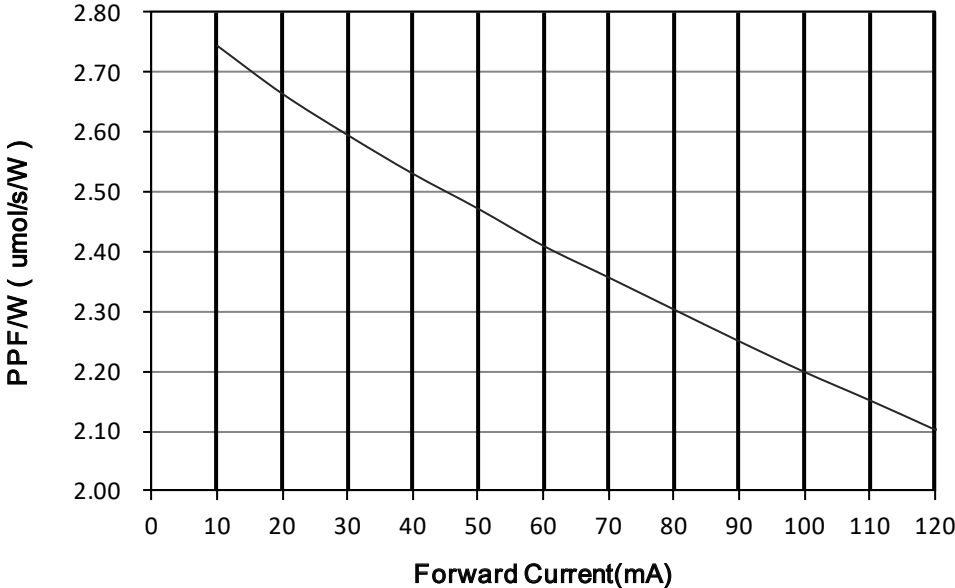

ELECTRICAL CHARACTERISTICS (Tj=25°C)

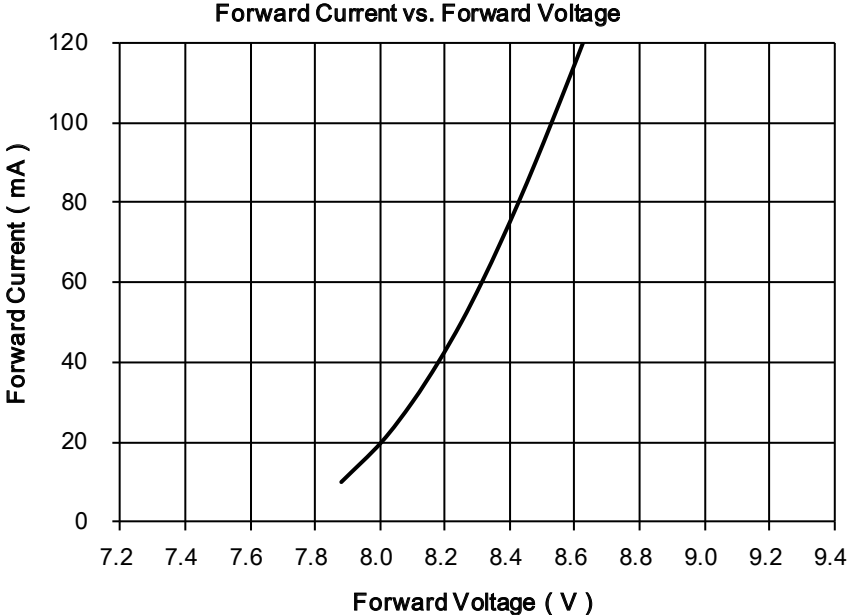

MAXIMUM CURRENT VS. AMBIENT TEMPERATURE

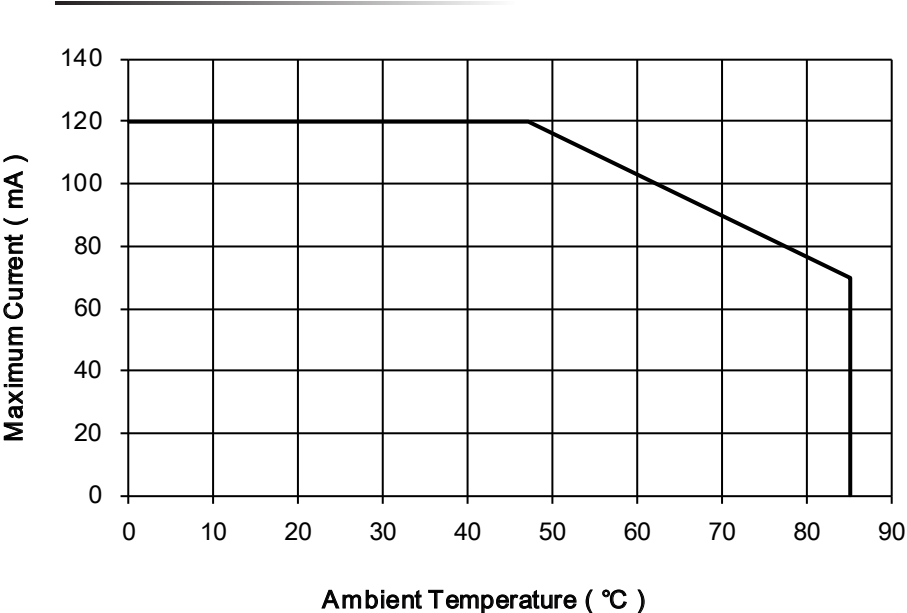

RELATIVE RADIANT FLUX VS. JUNCTION TEMPERATURE

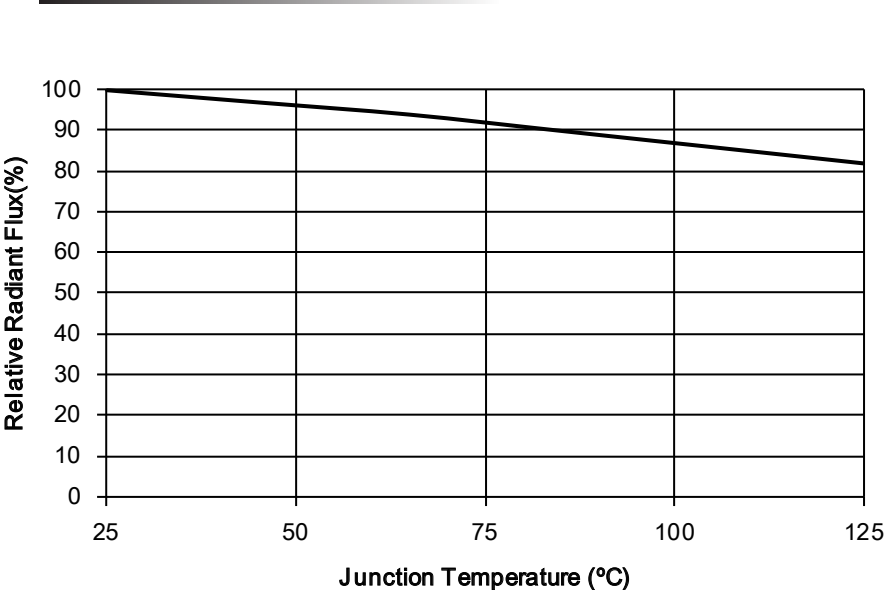

SORTING RANKS

(1) Luminous Flux (Tj=25°C)

Part Number	Condition	Rank			Unit
		P5	P6	P7	
ES-3030-PL-AI	100mA	75-80	80-85	85-90	lm

(2) Forward Voltage (Tj=25°C)

Rank	Condition	Min.	Max.	Unit
EB	100mA	8.5	8.8	V
EC		8.8	9.3	

Notes:

1. 10% tolerance for luminous intensity may be caused by measurement inaccuracy.
2. Measurement Uncertainty of the Forward Voltage : $\pm 0.1V$

(3) Chromaticity Bins

Part Number	Bin Code	Color Coordinates	
		X	Y
ES-3030 -PL-AI	PL	0.4800	0.4020
		0.4470	0.3810
		0.4510	0.3370
		0.4840	0.3580

CCT BIN Structure

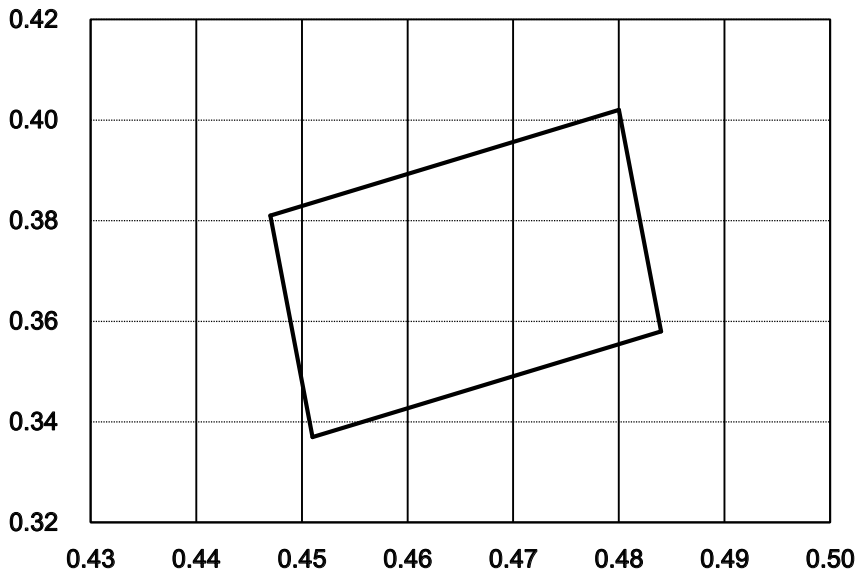

REFLOW SOLDERING CHARACTERISTICS

For Reflow Process:

Preheating : 140°C~160°C±5°C, within 2 minutes.

Operation heating : 260°C(Max.) within 10 seconds.(Max)

Gradual Cooling (Avoid quenching).

Lead solder		Lead-free solder	
Pre-heat	120-150°C	Pre-heat	150-200°C
Pre-heat time	120 sec.Max.	Pre-heat time	120 sec.Max.
Peak Temperature	240°C Max.	Peak Temperature	260°C Max.
Soldering time condition	10 sec.Max.	Soldering time condition	10 sec.Max.

<p style="text-align: center;">Lead Solder</p>	<p style="text-align: center;">Lead-free Solder</p>
--	---

Notes:

The encapsulated material of the LEDs is silicone . Therefore the LEDs have a soft surface on the top of package. The pressure to the top surface will be influence to the reliability of the LEDs. Precautions should be taken to avoid the strong pressure on the encapsulated part. So when using the picking up nozzle, the pressure on the silicone resin should be proper.

TAPE AND REEL

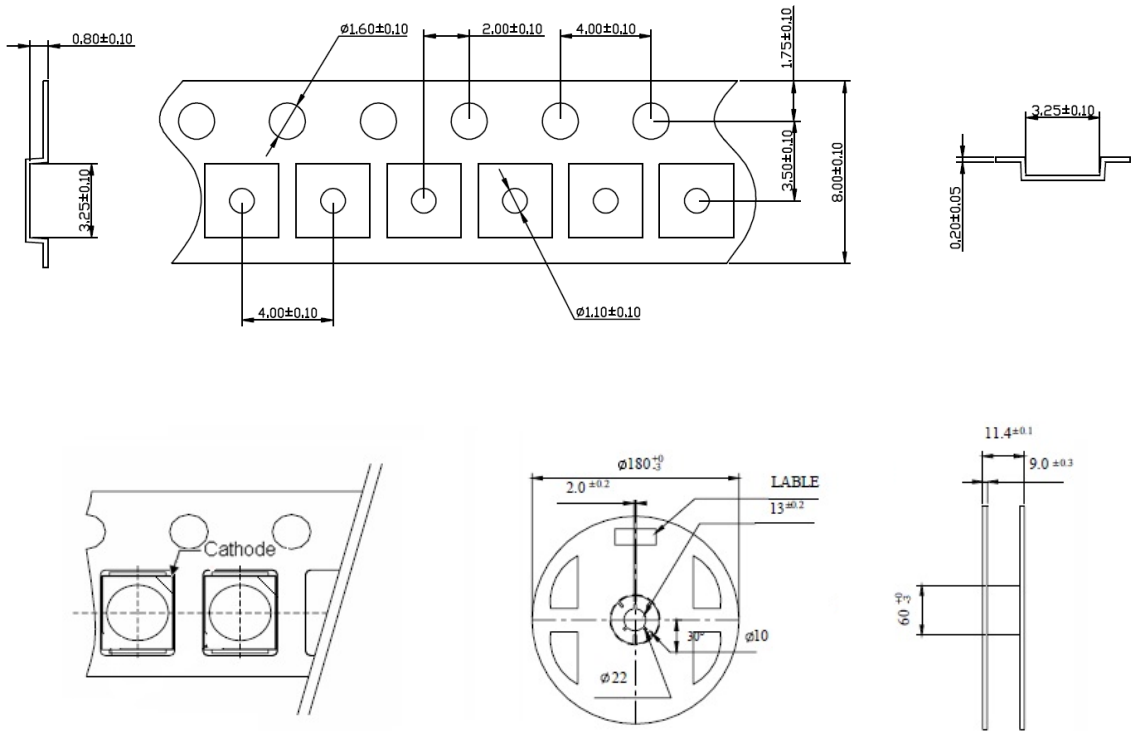

Notes:

- (1) Quantity : 3,500pcs/Reel
- (2) Cumulative Tolerance : Cumulative Tolerance/10 pitches to be $\pm 0.2\text{mm}$
- (3) Adhesion Strength of Cover Tape : Adhesion strength to be 0.1-0.7N when the cover tape is turned off from the carrier tape at the angle of 10° to the carrier tape
- (4) Package : P/N, Manufacturing data Code No. and quantity to be indicated on a damp proof Package.

PACKAGING

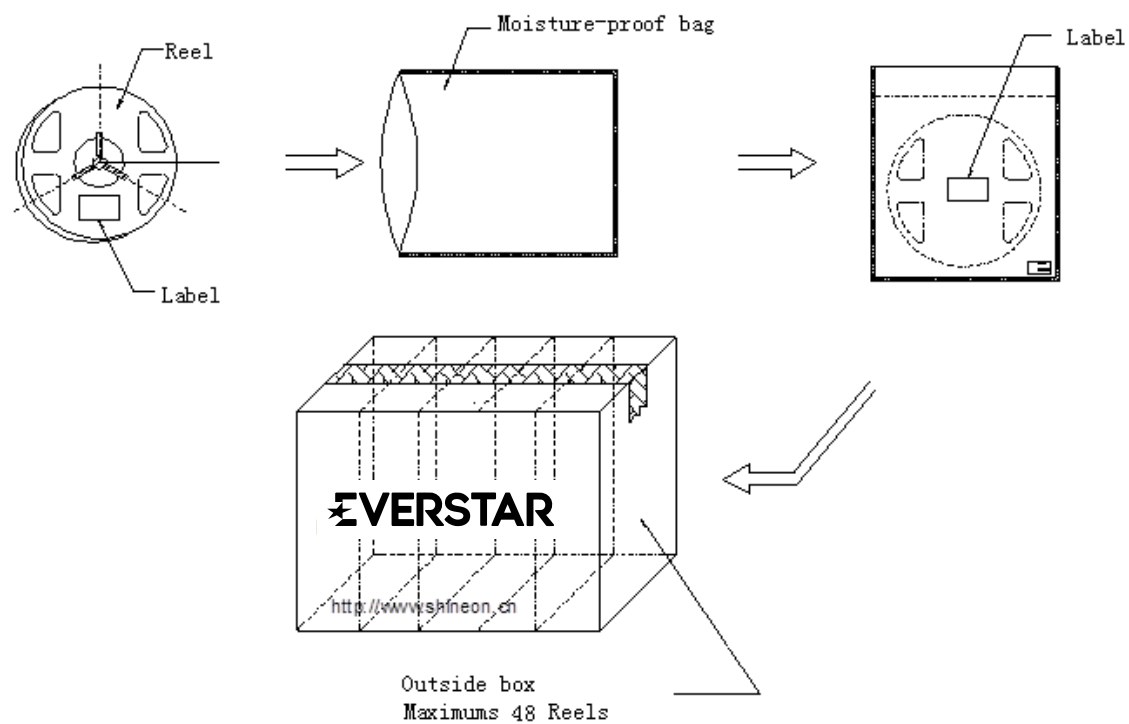

PRECAUTION FOR USE

- (1) This device should not be used in any type of fluid such as water, oil, organic solvent, etc. When washing is required, IPA should be used.
- (2) When the LEDs are illuminating, operating current should be decided after considering the ambient maximum temperature.
- (3) LEDs must be stored to maintain a clean atmosphere. If the LEDs are stored for 3 months or more after being shipped from Everstar, a sealed container with a nitrogen atmosphere should be used for storage.
- (4) The LEDs must be used within four weeks after opening the moisture proof packing. Repack unused Products with anti-moisture packing, fold to close any opening and then store in a dry place.
- (5) The appearance and specifications of the product may be modified for improvement without notice.
- (6) This LED is sensitive to the static electricity and surge. It is recommended to use a wrist Band or anti-electrostatic glove when handling the LEDs.
- (7) On manual soldering, a solder tip must be needed as grounded for usage. If over voltage which exceeds the absolute maximum rating is applied to LEDs, it will cause damage LEDs and result in destruction. Damaged LEDs will show some unusual characteristics such as leak current remarkably increase ,turn-on voltage becomes lower and the LEDs get unlighted at low current.